

**A****Application**

Series D6 hydraulic directional control valves are high performance, solenoid controlled, pilot operated, 2-stage, 4-way valves. They are available in 2 or 3-position styles. These valves are manifold mounted, and conform to NFPA's D08, CETOP 8 mounting patterns.

**Operation**

Series D61 directional valves consist of a 5-chamber style main body, a case hardened sliding spool, and a pilot valve or pilot operators (hydraulic or pneumatic).

**Features**

- Easy access mounting bolts.
- 210 Bar (3000 PSI) pressure rating.
- Flows to 380 LPM (100 GPM) depending on spool.
- Choice of four operator styles.
- Rugged four land spools.
- Low pressure drop.
- Phosphate finish.

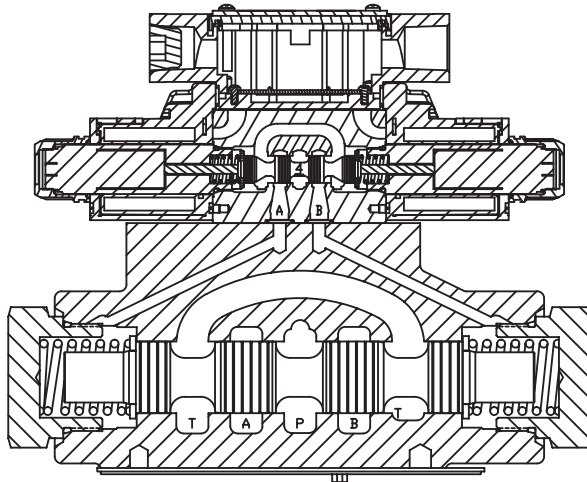
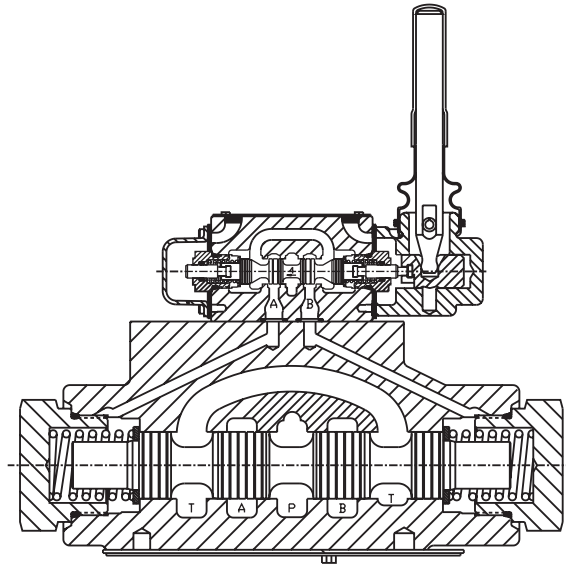
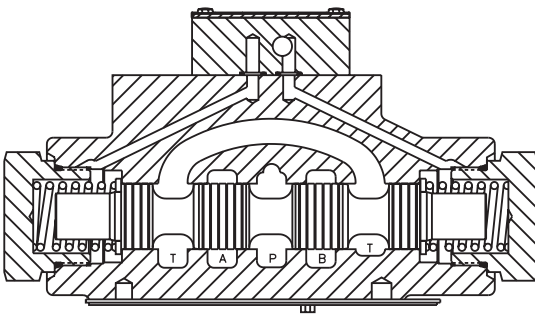
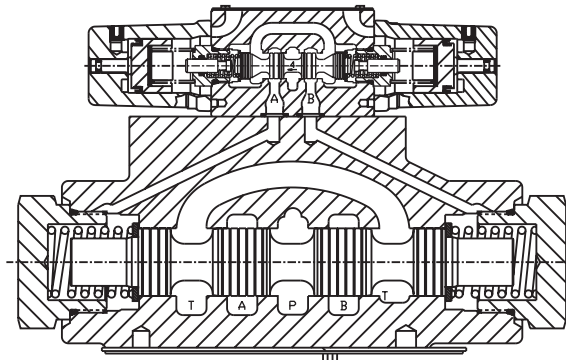
**D61\*W Solenoid Operated Plug-in Conduit Box****D61\*L Lever Operated****D61\*P Oil Pilot Operated****D61\*A Air Pilot Operated**

## General Description

Series D61VW directional control valves are 5-chamber, pilot operated, solenoid controlled valves. They are available in 2 or 3-position styles. These valves are manifold or subplate mounted, and conform to NFPA's D08, CETOP 8 mounting patterns.





## Operation

Series D61VW pilot operated valves are standard with low shock spools and pilot orifice. The orifice can be removed if a faster shift is required. It is recommended, however, that all systems operating above 138 Bar (2000 PSI) use the standard valve to avoid severe shock.

## Features

- Low pressure drop design.
- Hardened spools provide long life.
- Fast response option available.
- Explosion proof availability.
- Wide variety of voltages and electrical connection options.
- No tools required for coil removal.

## Specifications

<b>Mounting Pattern</b>	NFPA D08 CETOP 8, NG25
<b>Maximum Operating Pressure</b>	205 Bar (3000 PSI) Standard CSA  205 Bar (3000 PSI)
<b>Maximum Tank Line Pressure</b>	Internal Drain Model: 102 Bar (1500 PSI) AC Only 205 Bar (3000 PSI) DC Std./ AC Optional External Drain Model: 205 Bar (3000 PSI) CSA  102 Bar (1500 PSI)
<b>Maximum Drain Pressure</b>	102 Bar (1500 PSI) AC Standard 205 Bar (3000 PSI) DC Standard/ AC Optional CSA  102 Bar (1500 PSI)
<b>Minimum Pilot Pressure</b>	5.1 Bar* (75 PSI)
<b>Maximum Pilot Pressure</b>	205 Bar (3000 PSI) Standard CSA  205 Bar (3000 PSI)
<b>Nominal Flow</b>	189 LPM (50 GPM)
<b>Maximum Flow</b>	See Reference Data Chart

\* 6.9 Bar (100 PSI) for spool configurations 002, 007, 008, 009 & 014.

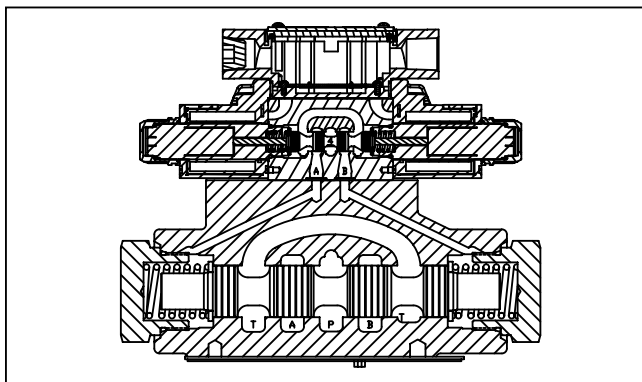
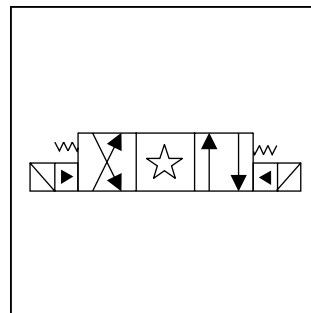
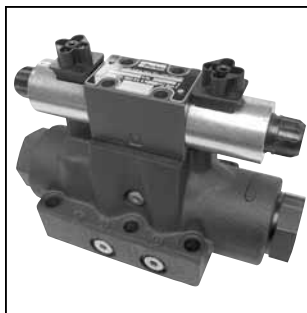

**A**

## Response Time

Response times (milliseconds) are measured at 205 Bar (3000 PSI) and 195 LPM (50 GPM) with various pilot pressures as indicated.

Solenoid Type	Pilot Pressure	Pull-In		Drop-Out	
		Std	Fast	Std	Fast
DC	500	130	100	80	80
	1000	90	90	80	80
	2000	80	80	80	80
AC	500	80	40	72	72
	1000	40	40	72	72
	2000	30	30	72	72

Because of the high drain line pressure transients generated during shifting, use of the fast response option is not recommended for pilot pressures exceeding 138 Bar (2000 PSI).

**A**

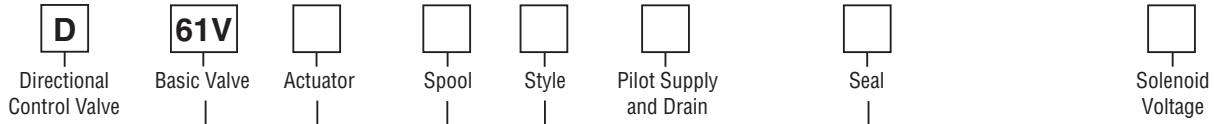

**NFPA D08, CETOP 8,  
 DIN NG25  
 Low Flow, D03 Pilot**

Code	Description
<b>W*</b>	<b>Solenoid, Wet Pin, Screw-in</b>
<b>HW*</b>	<b>Reversed Wiring</b>

\* Valve schematic symbols are per NFPA/ANSI standards, providing flow P to A when energizing solenoid A. Note operators reverse sides for #008 and #009 spools. See installation information for details. To configure per DIN standards (A coil over A port, B coil over B port) code valves as D61VHW\*\*\*.

Code	Description
<b>N</b>	<b>Nitrile</b>
<b>V</b>	<b>Fluorocarbon</b>

Code	Description
<b>1</b>	<b>Internal Pilot, External Drain</b>
<b>2</b>	<b>External Pilot, External Drain</b>
<b>3**</b>	<b>Internal Pilot w/Check, External Drain</b>
<b>4*</b>	<b>Internal Pilot, Internal Drain</b>
<b>5</b>	<b>External Pilot, Internal Drain</b>
<b>6**</b>	<b>Internal Pilot w/Check Internal Drain</b>

\* Not available with 002, 007, 008, 009 & 014 spools.  
 \*\* #3 and #6 bodies cannot be converted to other styles. Other pilot versions cannot be converted to styles 3 and 6.

Code	Description
<b>A*</b>	<b>24/50 VAC</b>
<b>D</b>	<b>120 VDC</b>
<b>G</b>	<b>198 VDC</b>
<b>J</b>	<b>24 VDC</b>
<b>K</b>	<b>12 VDC</b>
<b>N**</b>	<b>220/50 VAC</b>
<b>Q*</b>	<b>100/60 VAC</b>
<b>QD†</b>	<b>100 VAC/60 HZ 100 VAC/50 HZ</b>
<b>R</b>	<b>24/60 VAC</b>
<b>T</b>	<b>240/60 - 220/50 VAC</b>
<b>U</b>	<b>98 VDC</b>
<b>Y</b>	<b>120/60 - 110/50 VAC</b>
<b>Z</b>	<b>250 VDC</b>

\* High Watt only.  
 \*\* Explosion Proof only.  
 † Available in DIN only.

Code	Symbol	Code	Symbol
001		011	
002		012	
003		014	
004		015	
005		016	
006		021	
007		022	
008*			
009**			

\* 008 spool has closed crossover.  
 \*\* 009 spool has open crossover.

Code	Description	Symbol
<b>B*</b>	<b>Single solenoid, 2 position, spring offset. P to A and B to T in offset position.</b>	
<b>C</b>	<b>Double solenoid, 3 position, spring centered.</b>	
<b>D*</b>	<b>Double solenoid, 2 position, detent.</b>	
<b>E</b>	Single solenoid, 2 position, spring centered. P to B and A to T when energized.	
<b>F**</b>	Single solenoid, 2 position, spring offset, energized to center. Position spool spacer on A side. P to A and B to T in spring offset position.	
<b>H*</b>	<b>Single solenoid, 2 position, spring offset. P to B and A to T in offset position.</b>	
<b>K</b>	Single solenoid, 2 position, spring centered. P to A and B to T when energized.	
<b>M**</b>	Single solenoid, 2 position, spring offset, energized to center position. Spool spacer on B side. P to B and A to T in spring offset position.	

\* Available with 001, 002, 004, 011 and 014 spools only.  
 \*\* High watt coil only.

**Bold: Designates Tier I products and options.**

**Non-bold: Designates Tier II products and options. These products will have longer lead times.**



<div style="border: 1px solid black; width: 20px; height: 20px; margin: 0 auto;"></div> <p>Solenoid Connection</p>	<div style="border: 1px solid black; width: 20px; height: 20px; margin: 0 auto;"></div> <p>Coil Options</p>	<div style="border: 1px solid black; width: 20px; height: 20px; margin: 0 auto;"></div> <p>Tube Options</p>	<div style="border: 1px solid black; width: 20px; height: 20px; margin: 0 auto;"></div> <p>Manual Override Options</p>	<div style="border: 1px solid black; width: 20px; height: 20px; margin: 0 auto;"></div> <p>Electrical Options</p>	<div style="border: 1px solid black; width: 20px; height: 20px; margin: 0 auto;"></div> <p>Shift Response and Indication</p>	<div style="border: 1px solid black; width: 20px; height: 20px; margin: 0 auto;"></div> <p>Approvals</p>	<div style="border: 1px solid black; width: 20px; height: 20px; margin: 0 auto;"></div> <p>Valve Variations</p>	<div style="border: 1px dashed black; width: 20px; height: 20px; margin: 0 auto;"></div> <p>Design Series</p> <p>NOTE: Not required when ordering.</p>
--	---	---	--	---	--	--	---	--

<table border="1" style="width: 100%; border-collapse: collapse;"> <tr><th>Code</th><th>Description</th></tr> <tr><td><b>C*</b></td><td><b>Leadwire Conduit Box</b></td></tr> <tr><td>D**</td><td>Metric Plug (M12X1), DESINA</td></tr> <tr><td>E†</td><td>Explosion Proof</td></tr> <tr><td><b>G††</b></td><td><b>Plug-In Conduit Box</b></td></tr> <tr><td><b>J#</b></td><td><b>Deutsch (DT06-2S)</b></td></tr> <tr><td>M#</td><td>Metri-Pack (150)</td></tr> <tr><td><b>P</b></td><td><b>DIN with Plug</b></td></tr> <tr><td>S#</td><td>Dual Spade</td></tr> <tr><td><b>W†</b></td><td><b>DIN w/o Plug</b></td></tr> </table> <p>* No variations – See Plug-in.                  ** DC only, lights, diode surge suppressor, not CSA approved.                  † Not available with lights.                  †† Required for variations on conduit box style. Must have lights.                  # DC only, no lights, not CSA approved.</p>	Code	Description	<b>C*</b>	<b>Leadwire Conduit Box</b>	D**	Metric Plug (M12X1), DESINA	E†	Explosion Proof	<b>G††</b>	<b>Plug-In Conduit Box</b>	<b>J#</b>	<b>Deutsch (DT06-2S)</b>	M#	Metri-Pack (150)	<b>P</b>	<b>DIN with Plug</b>	S#	Dual Spade	<b>W†</b>	<b>DIN w/o Plug</b>	<table border="1" style="width: 100%; border-collapse: collapse;"> <tr><th>Code</th><th>Description</th></tr> <tr><td><b>Omit</b></td><td><b>Standard</b></td></tr> <tr><td>P</td><td>Extended with Boot</td></tr> <tr><td>T†</td><td>None</td></tr> </table> <p>† DC or AC Rectified only. Manual Override options not available with Explosion Proof.</p>	Code	Description	<b>Omit</b>	<b>Standard</b>	P	Extended with Boot	T†	None	<table border="1" style="width: 100%; border-collapse: collapse;"> <tr><th>Code</th><th>Description</th></tr> <tr><td><b>Omit</b></td><td><b>Standard Pressure</b></td></tr> <tr><td></td><td><b>103.5 Bar (1500 PSI) AC</b></td></tr> <tr><td></td><td><b>207 Bar (3000 PSI) DC</b></td></tr> <tr><td><b>H*</b></td><td><b>High Pressure, AC only</b></td></tr> <tr><td></td><td><b>207 Bar (3000 PSI)</b></td></tr> </table> <p>* Not available with CSA.</p>	Code	Description	<b>Omit</b>	<b>Standard Pressure</b>		<b>103.5 Bar (1500 PSI) AC</b>		<b>207 Bar (3000 PSI) DC</b>	<b>H*</b>	<b>High Pressure, AC only</b>		<b>207 Bar (3000 PSI)</b>
Code	Description																																									
<b>C*</b>	<b>Leadwire Conduit Box</b>																																									
D**	Metric Plug (M12X1), DESINA																																									
E†	Explosion Proof																																									
<b>G††</b>	<b>Plug-In Conduit Box</b>																																									
<b>J#</b>	<b>Deutsch (DT06-2S)</b>																																									
M#	Metri-Pack (150)																																									
<b>P</b>	<b>DIN with Plug</b>																																									
S#	Dual Spade																																									
<b>W†</b>	<b>DIN w/o Plug</b>																																									
Code	Description																																									
<b>Omit</b>	<b>Standard</b>																																									
P	Extended with Boot																																									
T†	None																																									
Code	Description																																									
<b>Omit</b>	<b>Standard Pressure</b>																																									
	<b>103.5 Bar (1500 PSI) AC</b>																																									
	<b>207 Bar (3000 PSI) DC</b>																																									
<b>H*</b>	<b>High Pressure, AC only</b>																																									
	<b>207 Bar (3000 PSI)</b>																																									

<table border="1" style="width: 100%; border-collapse: collapse;"> <tr><th>Code</th><th>Description</th></tr> <tr><td><b>Omit*</b></td><td><b>High Watt</b></td></tr> <tr><td>D**</td><td>Explosion Proof, EEXD ATEX</td></tr> <tr><td>E**</td><td>Explosion Proof, EEXME ATEX</td></tr> <tr><td>F†</td><td>Low Watt</td></tr> <tr><td>L††</td><td>10 Watt</td></tr> <tr><td>O**</td><td>Explosion Proof, MSHA</td></tr> <tr><td>T#</td><td>Explosion Proof, Ex d IIC ATEX/CSA</td></tr> <tr><td>U**</td><td>Explosion Proof, UL/CSA</td></tr> </table> <p>* AC ambient temperature must not exceed 60°C (140°F).                  ** 60 Hz only on AC, no options.                  † AC only.                  †† DC and AC rectified only.                  # J, K and Y voltages only. Dual frequency on AC, no options.</p>	Code	Description	<b>Omit*</b>	<b>High Watt</b>	D**	Explosion Proof, EEXD ATEX	E**	Explosion Proof, EEXME ATEX	F†	Low Watt	L††	10 Watt	O**	Explosion Proof, MSHA	T#	Explosion Proof, Ex d IIC ATEX/CSA	U**	Explosion Proof, UL/CSA	<table border="1" style="width: 100%; border-collapse: collapse;"> <tr><th>Code</th><th>Description</th></tr> <tr><td><b>Omit</b></td><td><b>No Options</b></td></tr> <tr><td>J*</td><td>Diode Surge Suppressor</td></tr> <tr><td>Z†</td><td>Rectified Coil</td></tr> </table> <p>* DC only. DIN coil must include plug with lights.                  † DC tube standard.</p>	Code	Description	<b>Omit</b>	<b>No Options</b>	J*	Diode Surge Suppressor	Z†	Rectified Coil	<table border="1" style="width: 100%; border-collapse: collapse;"> <tr><th>Code</th><th>Description</th></tr> <tr><td><b>Omit</b></td><td><b>Standard Response, No Switch</b></td></tr> <tr><td>I3</td><td>Monitor Switch, 'A' &amp; 'B' Port End</td></tr> <tr><td>I6</td><td>Monitor Switch, 'A' &amp; 'B' Port Start</td></tr> </table> <p>Note: Not CE or CSA approved. Not available with "F" or "M" styles.</p>	Code	Description	<b>Omit</b>	<b>Standard Response, No Switch</b>	I3	Monitor Switch, 'A' & 'B' Port End	I6	Monitor Switch, 'A' & 'B' Port Start
Code	Description																																			
<b>Omit*</b>	<b>High Watt</b>																																			
D**	Explosion Proof, EEXD ATEX																																			
E**	Explosion Proof, EEXME ATEX																																			
F†	Low Watt																																			
L††	10 Watt																																			
O**	Explosion Proof, MSHA																																			
T#	Explosion Proof, Ex d IIC ATEX/CSA																																			
U**	Explosion Proof, UL/CSA																																			
Code	Description																																			
<b>Omit</b>	<b>No Options</b>																																			
J*	Diode Surge Suppressor																																			
Z†	Rectified Coil																																			
Code	Description																																			
<b>Omit</b>	<b>Standard Response, No Switch</b>																																			
I3	Monitor Switch, 'A' & 'B' Port End																																			
I6	Monitor Switch, 'A' & 'B' Port Start																																			

See next page

<b>Code</b>	<b>Description</b>
<b>Omit*</b>	<b>High Watt</b>
D**	Explosion Proof, EEXD ATEX
E**	Explosion Proof, EEXME ATEX
F†	Low Watt
L††	10 Watt
O**	Explosion Proof, MSHA
T#	Explosion Proof, Ex d IIC ATEX/CSA
U**	Explosion Proof, UL/CSA

<b>Code</b>	<b>Description</b>
<b>Omit</b>	<b>No Options</b>
J*	Diode Surge Suppressor
Z†	Rectified Coil

<b>Code</b>	<b>Description</b>
<b>Omit</b>	<b>Standard Response, No Switch</b>
I3	Monitor Switch, 'A' & 'B' Port End
I6	Monitor Switch, 'A' & 'B' Port Start

\* AC ambient temperature must not exceed 60°C (140°F).  
 \*\* 60 Hz only on AC, no options.  
 † AC only.  
 †† DC and AC rectified only.  
 # J, K and Y voltages only. Dual frequency on AC, no options.

**Valve Weight:**  
 Double Solenoid 12.1 kg (26.6 lbs.)

**Seal Kit:**  
 Nitrile SKD61VWN91  
 Fluorocarbon SKD61VWV91

**Mounting Bolt Kits**

UNC Bolt Kits for use with D6 and D8 Directional Control Valves & Sandwich Valves				
	Number of Sandwich Valves @ 2.75" (70mm) thickness			
	0	1	2	3
D6	BK227 2.50"	BK121 5.25"	BK122 8.00"	BK123 10.75"
D6 plus tapping plate	BK161 3.50"	BK170 6.25"	BK171 9.00"	BK172 11.75"
D8	BK228 3.00"	BK131 5.75"	BK132 8.50"	BK133 11.25"
D8 plus tapping plate	BK173 4.00"	BK174 6.75"	BK175 9.50"	BK114 12.125"

Note: All bolts are SAE grade 8, 1/2-13 UNC-3A thread, torque to 133 N.m. (100 ft.-lbs.)

**Bold: Designates Tier I products and options.**

**Non-bold: Designates Tier II products and options. These products will have longer lead times.**



**Valve Variations**

**A**

Code	Description
5*	<b>Signal Lights – Standard</b>
	<b>Signal Lights – Hirsch. (DIN with plug)</b>
7B**	Manaplug – Brad Harrison (12x1) Micro with lights
56**	<b>Manaplug (Mini) with Lights</b>
20	<b>Fast Response</b>
1C**	<b>Manaplug (Mini) Single Sol. 5-pin, with Lights</b>
1D**	Manaplug (Micro) Single Sol. 5-pin, with Lights
1G**	Manaplug (Mini) Single Sol. 5-pin, with Stroke Adjust 'A' & 'B' End and Lights
1H**	Manaplug (Micro) Single Sol. 5-pin, with Stroke Adjust 'A' & 'B' End and Lights
1M**	Manaplug Opposite Normal
1P	Painted Body
1R	Stroke Adjust 'A' & 'B' End with Pilot Choke Meter In
3A	<b>Pilot Choke Meter Out</b>
3B	<b>Pilot Choke Meter In</b>
3C	<b>Pilot Pressure Reducer</b>
3D	Stroke Adjust 'B' End
3E	Stroke Adjust 'A' End
3F	Stroke Adjust 'A' & 'B' End
3G*	<b>Pilot Choke Meter Out with Lights</b>
3H*	<b>Pilot Choke Meter In with Lights</b>
3J*	Pilot Pressure Reducer with Lights
3K	Pilot Choke Meter Out with Stroke Adjust 'A' & 'B' End
3L**	Pilot Choke Meter Out, Stroke Adjust 'A' & 'B' End with Lights and Manaplug — Brad Harrison Mini
3M	Pilot Choke Meter Out, Pilot Pressure Reducer, Stroke Adjust 'A' & 'B' End
3R	Pilot Choke Meter Out & Pilot Pressure Reducer
3S**	Lights, Mini Manaplug, Pilot Choke Meter Out
7Y**	M12x1 Manaplug (4-pin), Special Wiring, and Lights

\* DESINA, plug-in conduit box, and DIN with plug styles only.

\*\* Must have plug-in style conduit box.



**Reference Data**

Model	Spool Symbol	Maximum Flow, LPM (GPM) 207 Bar (3000 PSI) w/o Malfunction	Model	Spool Symbol	Maximum Flow, LPM (GPM) 207 Bar (3000 PSI) w/o Malfunction
D61V*001		390 (100)	D61V*008		312 (80)
D61V*002		312 (80)	D61V*009		312 (80)
D61V*003		390 (100)	D61V*011		390 (100)
D61V*004		390 (100)	D61V*012		137 (35)
D61V*005		390 (100)	D61V*014		195 (50)
D61V*006		390 (100)	D61V*015		390 (100)
D61V*007		195 (50)	D61V*016		390 (100)

**D61V\* Series Pressure Drop Chart**

The following chart provides the flow vs. pressure drop curve reference for the Series D61V valves by spool type.

VISCOSITY CORRECTION FACTOR							
Viscosity (SSU)	75	150	200	250	300	350	400
% of ΔP (Approx.)	93	111	119	126	132	137	141

Curves were generated using 100 SSU hydraulic oil. For any other viscosity, pressure drop will change as per chart.

D61VW Pressure Drop Reference Chart -- Curve Number					
Spool No.	P-A	P-B	P-T	A-T	B-T
001	3	3	-	1	2
002	4	4	5	4	5
003	3	3	-	4	2
004	3	3	-	4	5
005	3	4	-	1	2
006	4	4	-	1	2
007	4	4	7	1	5
008/009	3	3	7	4	6
011	3	3	-	1	2
012	3	3	8	4	5
014	4	4	-	2	1
015	3	3	-	2	4
016	4	3	-	2	1

**Performance Curves**

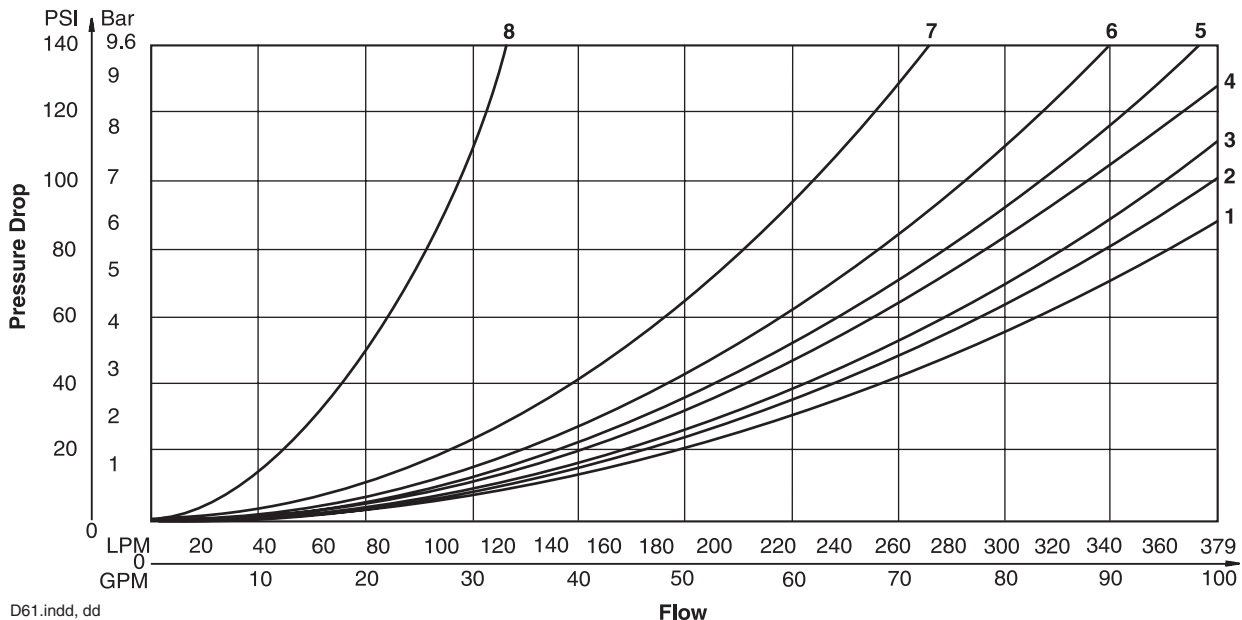

D61.indd, dd





**Solenoid Ratings**

<b>Insulation System</b>	Class F
<b>Allowable Deviation from rated voltage</b>	-15% to +10% for DC and AC rectified coils -5% to +5% for AC Coils
<b>Armature</b>	Wet pin type
<b>CSA File Number</b>	LR60407
<b>Environmental Capability</b>	DC Solenoids meet NEMA 4 and IP67 when properly wired and installed. Contact HVD for AC coil applications.

**Explosion Proof Solenoid Ratings\***

<b>U.L. &amp; CSA (EU)</b>	Class I, Div 1 & 2, Groups C & D Class II, Div 1 & 2, Groups E, F & G As defined by the N.E.C.
<b>MSHA (EO)</b>	Complies with 30CFR, Part 18
<b>ATEX (ED)</b>	Complies with ATEX requirements for: Exd, Group IIB; EN50014: 1999+ Amds. 1 & 2, EN50018: 2000
<b>ATEX &amp; CSA/US (ET)</b>	Complies with ATEX EN60079-0, EN60079-1 Ex d IIC; CSA/US Ex d IIC, AEx d IIC for Class I, Zone 1, UL1203, UL1604, CSA E61241,1 Class II, Div 1

\* Allowable Voltage Deviation ±10%.  
 Note that Explosion Proof AC coils are single frequency only.

Code		Voltage	In Rush Amps Amperage	In Rush VA	Holding Amps @ 3MM	Watts	Resistance
Voltage Code	Power Code						
D	L	120 VDC	N/A	N/A	0.09 Amps	10 W	1584.00 ohms
D	Omit	120 VDC	N/A	N/A	0.26 Amps	30 W	528.00 ohms
G	Omit	198 VDC	N/A	N/A	0.15 Amps	30 W	1306.80 ohms
J	L	24 VDC	N/A	N/A	0.44 Amps	10 W	51.89 ohms
J	Omit	24 VDC	N/A	N/A	1.32 Amps	30 W	17.27 ohms
K	L	12 VDC	N/A	N/A	0.88 Amps	10 W	12.97 ohms
K	Omit	12 VDC	N/A	N/A	2.64 Amps	30 W	4.32 ohms
L	L	6 VDC	N/A	N/A	1.67 Amps	10 W	3.59 ohms
L	Omit	6 VDC	N/A	N/A	5.00 Amps	30 W	1.20 ohms
Q	Omit	100 VAC / 60 Hz	2.05 Amps	170 VA	0.77 Amps	30 W	19.24 ohms
QD	F	100 VAC / 60 Hz	1.35 Amps	135 VA	0.41 Amps	18 W	31.20 ohms
QD	F	100 VAC / 50 Hz	1.50 Amps	150 VA	0.57 Amps	24 W	31.20 ohms
R	F	24/60 VAC, Low Watt	6.67 Amps	160 VA	2.20 Amps	23 W	1.52 ohms
T	Omit	240/60 VAC	0.83 Amps	199 VA	0.30 Amps	30 W	120.40 ohms
T	Omit	220/50 VAC	0.87 Amps	191 VA	0.34 Amps	30 W	120.40 ohms
T	F	240/60 VAC, Low Watt	0.70 Amps	168 VA	0.22 Amps	21 W	145.00 ohms
T	F	220/50 VAC, Low Watt	0.75 Amps	165 VA	0.26 Amps	23 W	145.00 ohms
U	L	98 VDC	N/A	N/A	0.10 Amps	10 W	960.00 ohms
U	Omit	98 VDC	N/A	N/A	0.31 Amps	30W	288.00 ohms
Y	Omit	120/60 VAC	1.7 Amps	204 VA	0.60 Amps	30 W	28.20 ohms
Y	Omit	110/50 VAC	1.7 Amps	187 VA	0.68 Amps	30 W	28.20 ohms
Y	F	120/60 VAC, Low Watt	1.40 Amps	168 VA	0.42 Amps	21 W	36.50 ohms
Y	F	110/50 VAC, Low Watt	1.50 Amps	165 VA	0.50 Amps	23 W	36.50 ohms
Z	L	250 VDC	N/A	N/A	0.04 Amps	10 W	6875.00 ohms
Z	Omit	250 VDC	N/A	N/A	0.13 Amps	30 W	1889.64 ohms
<b>Explosion Proof Solenoids</b>							
R		24/60 VAC	7.63 Amps	183 VA	2.85 Amps	27 W	1.99 ohms
T		240/60 VAC	0.76 Amps	183 VA	0.29 Amps	27 W	1.34 ohms
N		220/50 VAC	0.77 Amps	169 VA	0.31 Amps	27 W	1.38 ohms
Y		120/60 VAC	1.60 Amps	192 VA	0.58 Amps	27 W	33.50 ohms
P		110/50 VAC	1.47 Amps	162 VA	0.57 Amps	27 W	34.70 ohms
K		12 VDC	N/A	N/A	2.75 Amps	33 W	4.36 ohms
J		24 VDC	N/A	N/A	1.38 Amps	33 W	17.33 ohms
<b>"ET" Explosion Proof Solenoids</b>							
K		12 VDC	N/A	N/A	1.00 Amps	12 W	12.00 ohms
J		24 VDC	N/A	N/A	1.00 Amps	13 W	44.30 ohms
Y		120/60-50 VAC	N/A	N/A	0.16 Amps	17 W	667.00 ohms

D61.indd, dd



Inch equivalents for millimeter dimensions are shown in (\*\*)

**Plug-in Conduit Box, Double AC Solenoid**

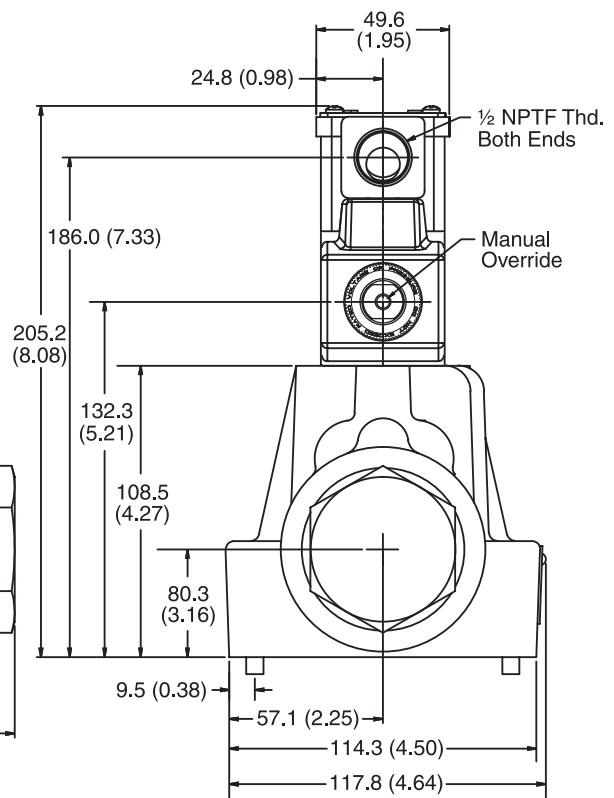
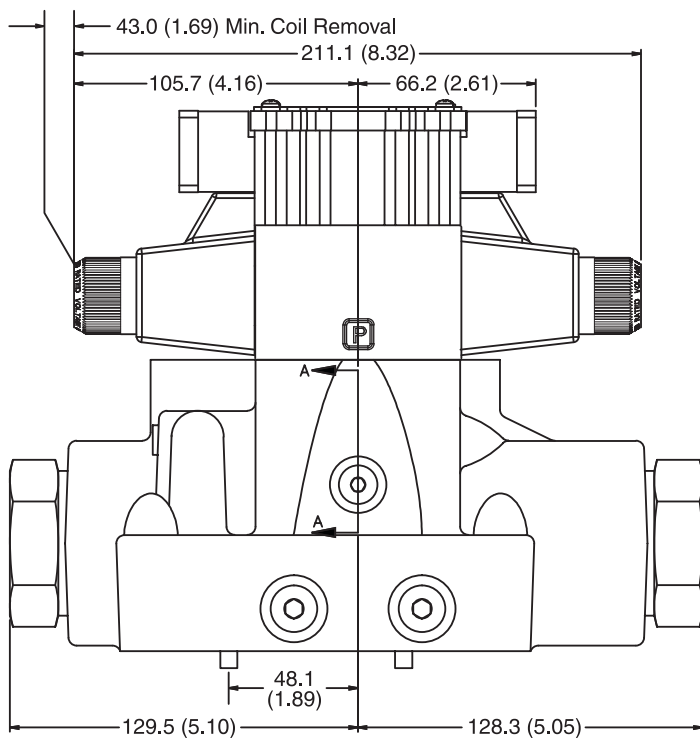
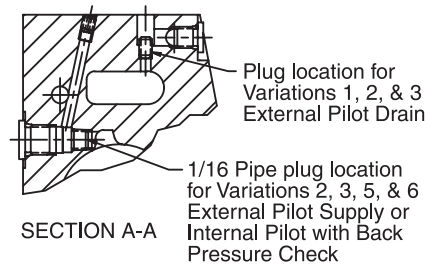
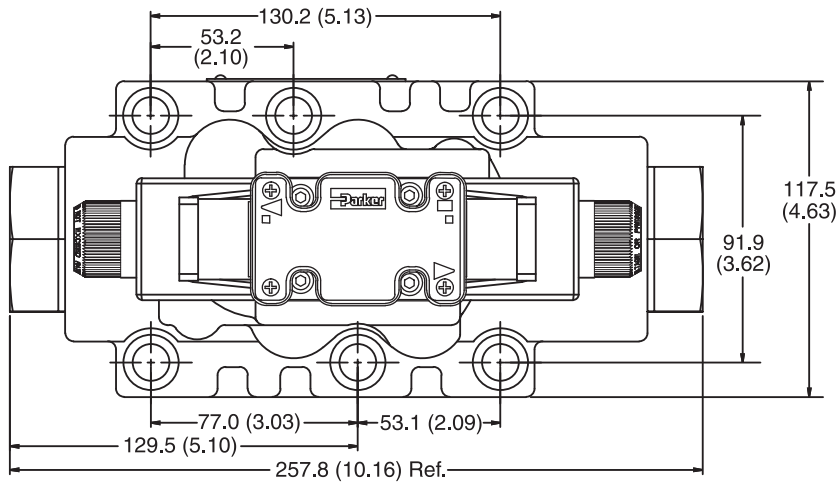

**Note:** 41.9mm (1.65") from bottom of bolt hole counterbore to bottom of valve.





Inch equivalents for millimeter dimensions are shown in (\*\*)

**A**

**Plug-in Conduit Box and Stroke Adjust, Double AC Solenoid**

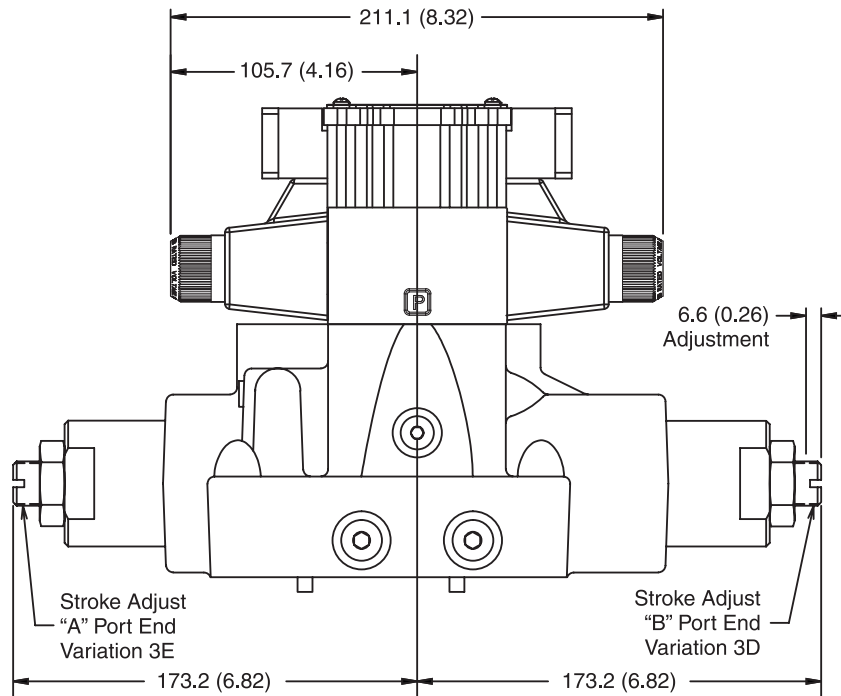

**Note:** 41.9mm (1.65") from bottom of bolt hole counterbore to bottom of valve.

**Plug-in Conduit Box, Single AC Solenoid**

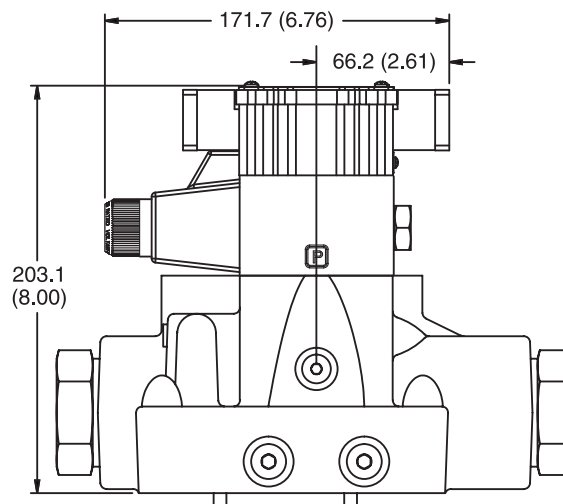

**Note:** 41.9mm (1.65") from bottom of bolt hole counterbore to bottom of valve.

Inch equivalents for millimeter dimensions are shown in (\*\*)

**Plug-in Conduit Box, Double DC Solenoid**

**A**

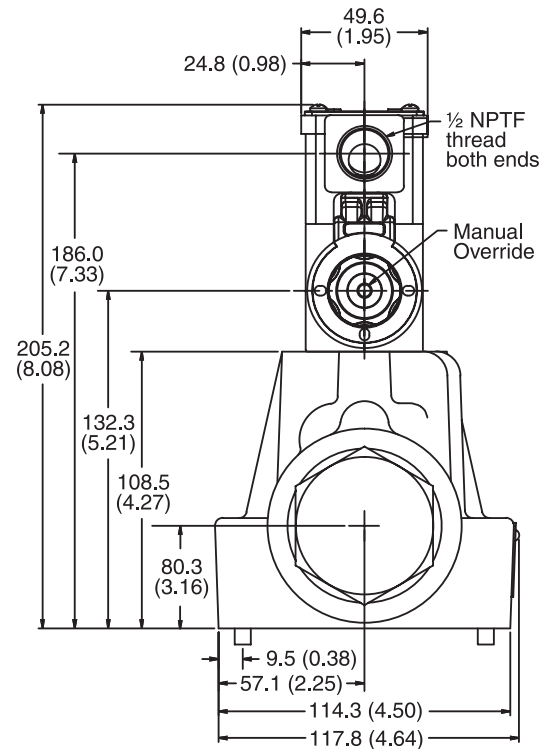
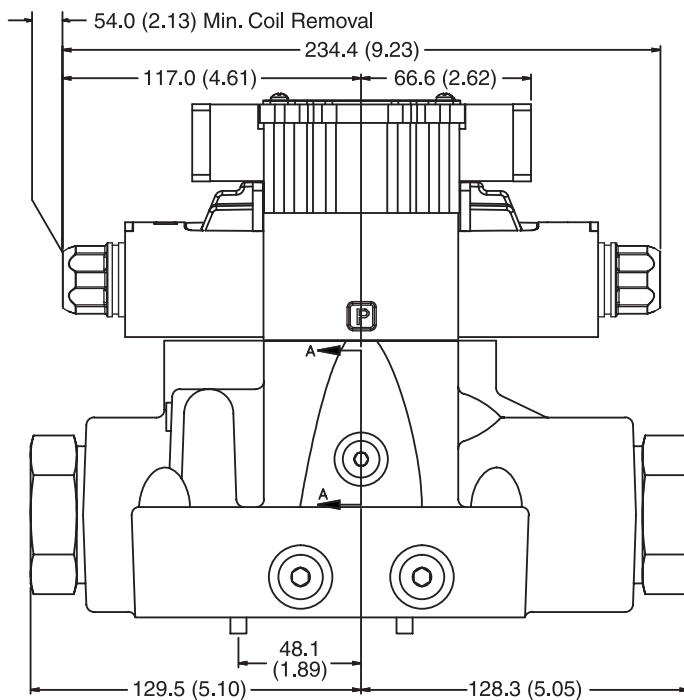
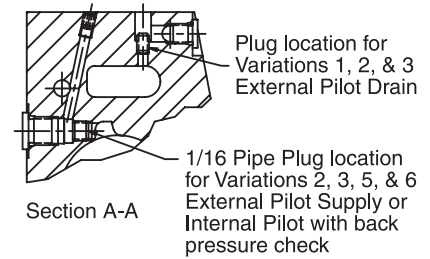
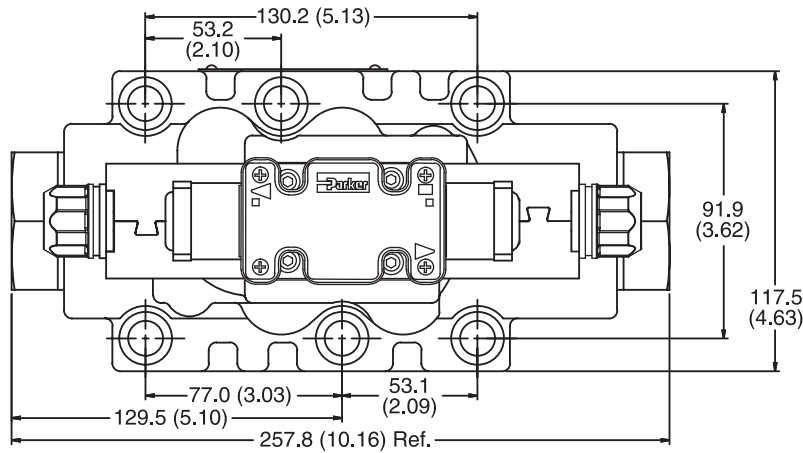

**Note:** 41.9mm (1.65") from bottom of bolt hole counterbore to bottom of valve.



Inch equivalents for millimeter dimensions are shown in (\*\*)

**A**

**Plug-in Conduit Box and Stroke Adjust, Double DC Solenoid**

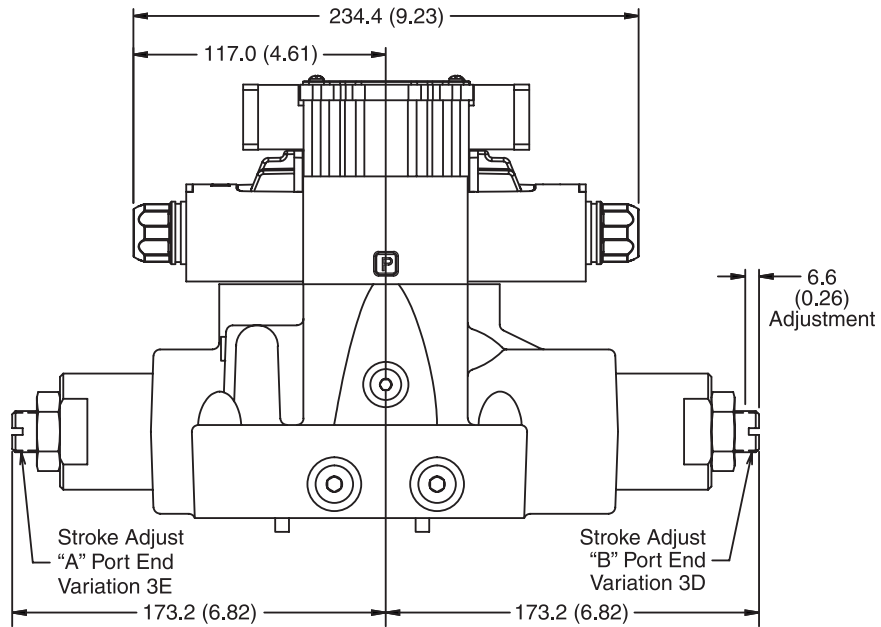

**Note:** 41.9mm (1.65") from bottom of bolt hole counterbore to bottom of valve.

**Hirschmann and Pilot Choke Control, Double DC Solenoid**

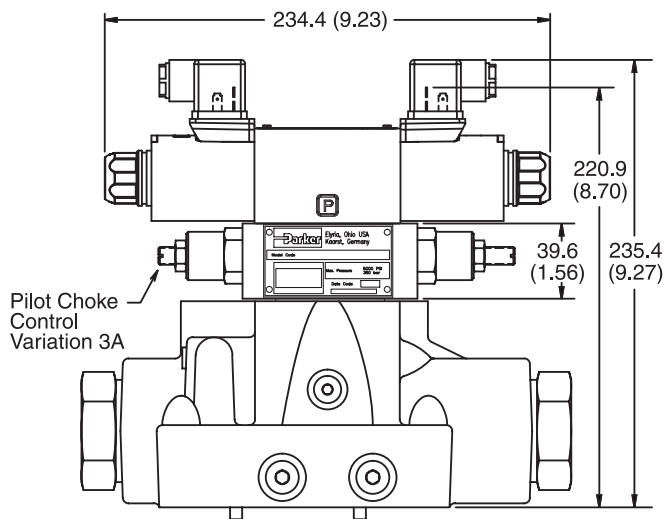

**Plug-in Conduit Box, Single DC Solenoid**

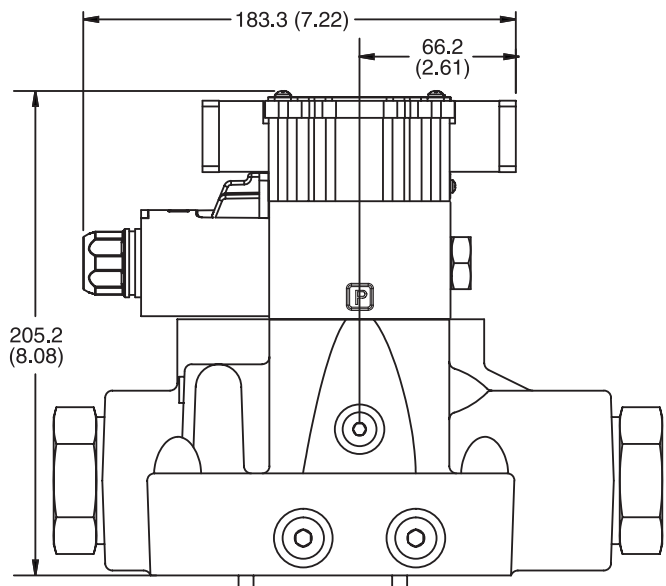

Inch equivalents for millimeter dimensions are shown in (\*\*)

**Plug-in Conduit Box, Double DC Solenoid with Variation I3 (Monitor Switch)**

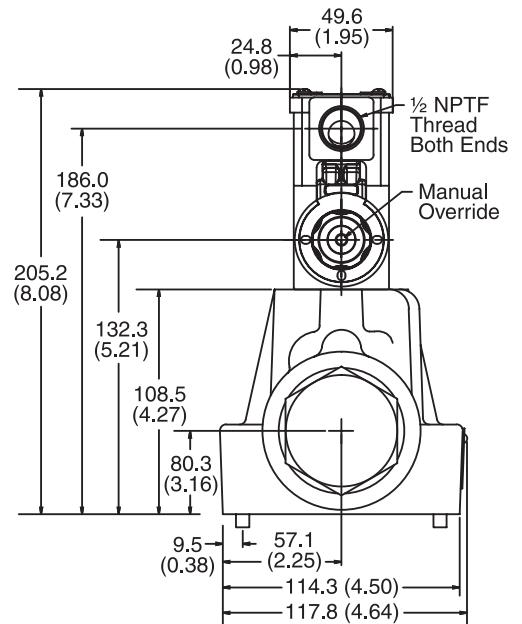
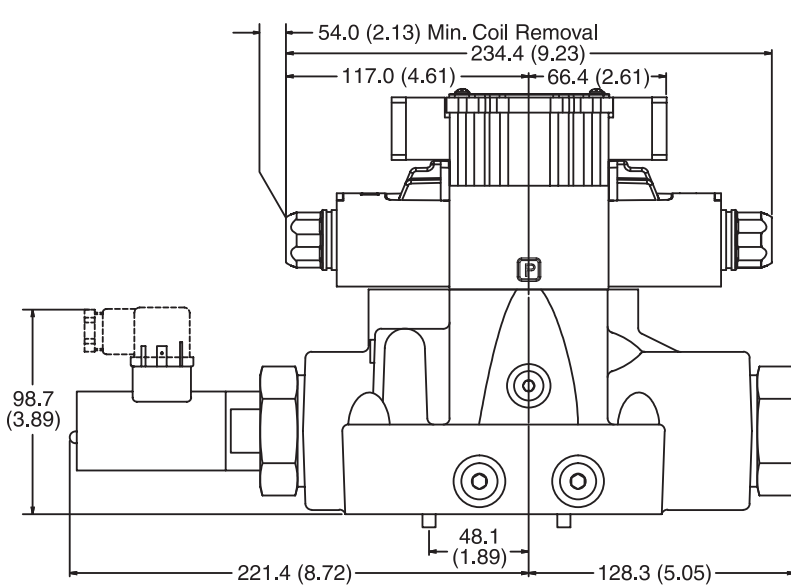
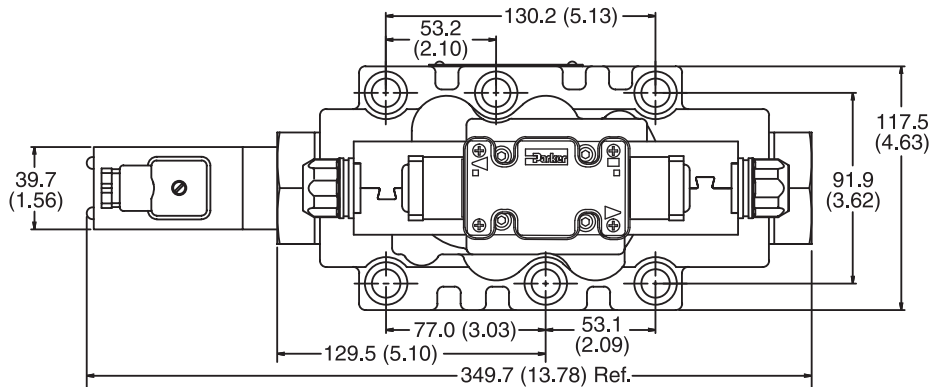

**Monitor Switch (Variation I3 and I6)**

This feature provides for electrical confirmation of the spool shift. This can be used in safety circuits, to assure proper sequencing, etc.

**Switch Data**

Pin 1 and Pin 3 have outputs equal to the input. When the monitor switch has the output to Pin 1, Pin 3 will have an output of zero, and vice-versa. When the valve is switched, Pin 1 and Pin 3 will switch outputs.

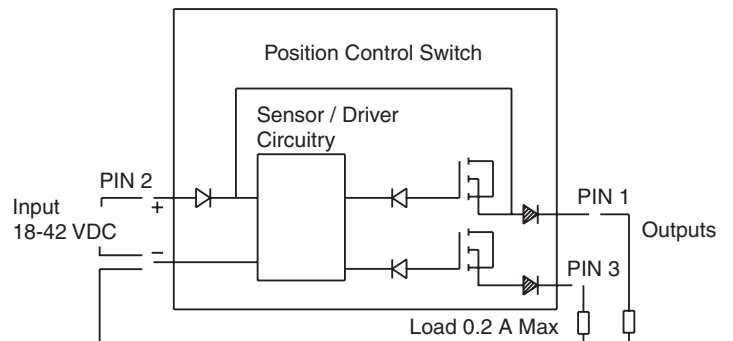



**Manaplug (Options 6, 56, 1A & 1C)**

- Interface – Brad Harrison Plug
- 3-Pin for Single Solenoid
  - 5-Pin for Double Solenoid

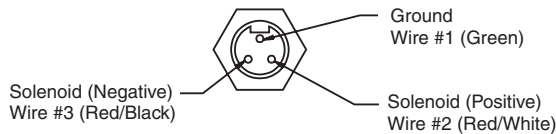

**3-Pin Manaplug (Mini) with Lights**

Single Solenoid Valves – Installed Opposite Side of Solenoid

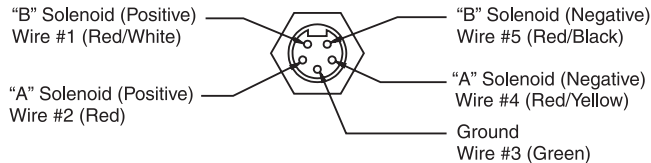

**5-Pin Manaplug (Mini) with Lights**

Single Solenoid Valves – Installed Opposite Side of Solenoid  
 Double Solenoid Valves – Installed Over "A" Solenoid  
 ("A" and "B" Solenoids Reversed for #8 and #9 Spools)

**Micro Connector Options (7A, 7B, 1B & 1D)**

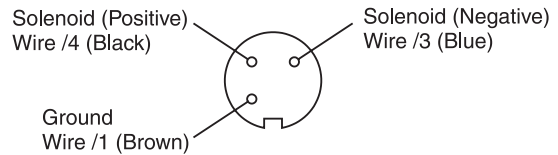

**3-Pin Manaplug (Micro) with Lights**

Single Solenoid Valves – Installed Opposite Side of Solenoid

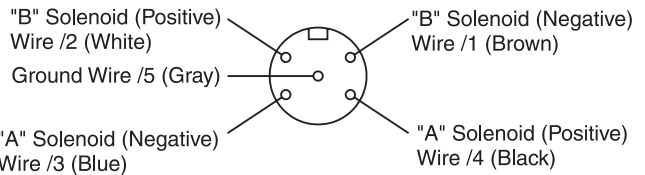

**5-Pin Manaplug (Micro) with Lights**

Single Solenoid Valves – Installed Opposite Side of Solenoid  
 Double Solenoid Valves – Installed Over "A" Solenoid  
 ("A" and "B" Solenoids Reversed for #8 and #9 Spools)

**Pins are as seen on valve (male pin connectors)**

**Manaplug – Electrical Mini Plug**

- EP336-30** 3 Pin Plug
- EP316-30** 5 Pin Plug (Double Solenoid)
- EP31A-30** 5 Pin Plug (Single Solenoid)

**Manaplug – Electrical Micro Plug**

- EP337-30** 3 Pin Plug
- EP317-30** 5 Pin Plug (Double Solenoid)
- EP31B-30** 5 Pin Plug (Single Solenoid)

**Conduit Box Option C**

- No Wiring Options Available

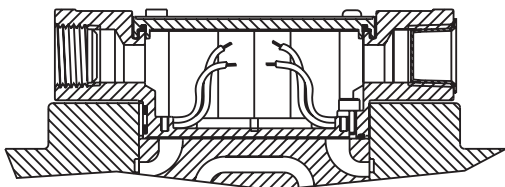

**Signal Lights (Option 5) — Plug-in Only**

- LED Interface
- Meets Nema 4/IP67

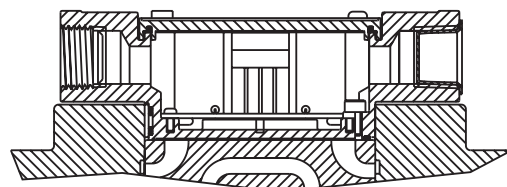

**Hirschmann Plug with Lights (Option P5)  
 ISO 4400/DIN 43650 Form "A"**

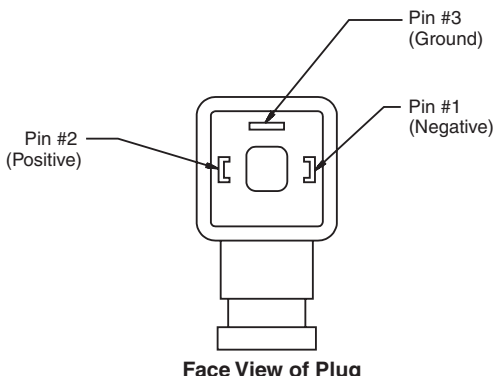

Face View of Plug

**DESINA Connector (Option D)  
 M12 pin assignment  
 Standard**

- 1 = Not used
- 2 = Not used
- 3 = 0V
- 4 = Signal (24 V)
- 5 = Earth Ground

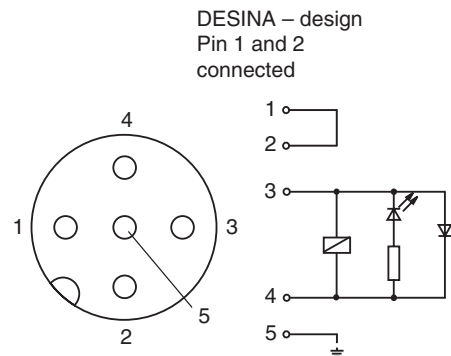

DESINA – design  
 Pin 1 and 2  
 connected

**Pins are as seen on valve (male pin connectors)**

### General Description

Series D61VA directional control valves are 5-chamber, air pilot operated valves. They are available in 2 or 3-position styles. These valves are manifold or subplate mounted, and conform to NFPA's D08, CETOP 8 mounting patterns.

### Specifications

<b>Mounting Pattern</b>	NFPA D08, CETOP 8, NG25
<b>Max. Operating Pressure</b>	207 Bar (3000 PSI)
<b>Max. Tank Pressure</b>	Internal Drain Model: 34 Bar (500 PSI) External Drain Model: 207 Bar (3000 PSI)
<b>Max. Drain Pressure</b>	34 Bar (500 PSI)
<b>Maximum Flow</b>	See Reference Data
<b>Pilot Pressure</b>	Air Min. 3.4 Bar (50 PSI) Air Max. 10.2 Bar (150 PSI)
<b>Response Time</b>	Varies with pilot line size and length, pilot pressure, pilot valve shift time & flow capacity (GPM)

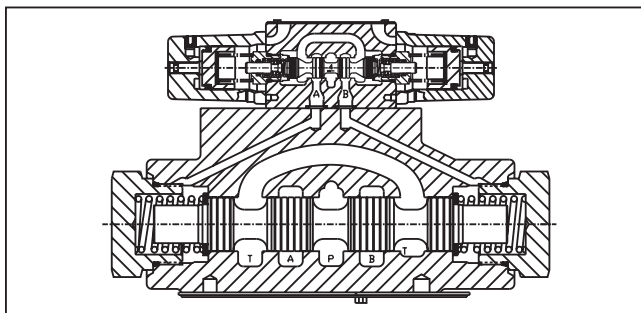
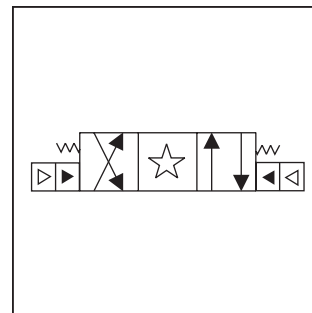
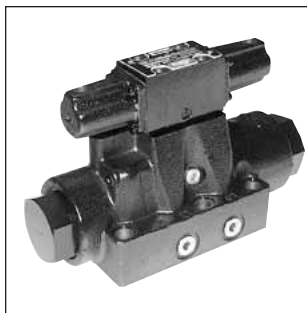

**A**

### Ordering Information

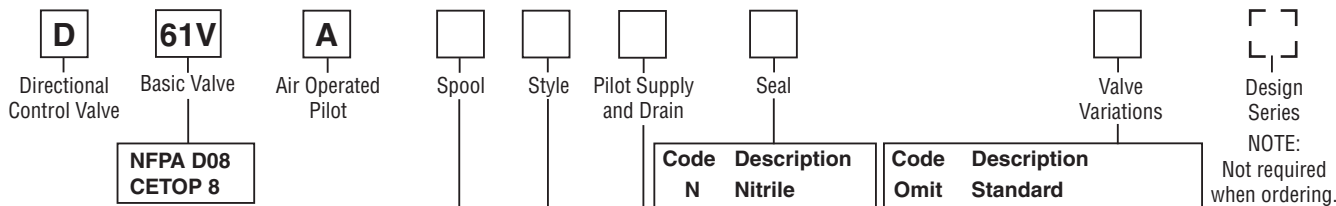

Code	Symbol	Code	Symbol
001		008*	
002		009**	
004		011	
		012	

\* 008 spool has closed crossover.  
 \*\* 009 spool has open crossover.

Valve schematic symbols are per NFPA/ANSI standards, providing flow P to A when energizing operator A. Note operators reverse sides for #8 and #9 spools. See installation information for details.

- Valve Weight:** 12.4 kg (27.3 lbs.)
- Standard Bolt Kit:** BK227
- Metric Bolt Kit:** BKM227
- Seal Kit:**
  - Nitrile SKD61VA
  - Fluorocarbon SKD61VAV

Code	Description
N	Nitrile
V	Fluorocarbon
1	Int. pilot/Ext. drain
2	Ext. pilot/Ext. drain
4#	Int. pilot/Int. drain
5	Ext. pilot/Int. drain

# Not available with 002, 008 & 009 spools.

Code	Description
Omit	Standard
7	Pilot Choke – Meter-out
8	Stroke Adj. 'B' End
9	Stroke Adj. 'A' End
60	Pilot Choke – Meter-in
89	Stroke Adj. 'A' & 'B' Ends
90	1/4 BSPP Threads

NOTE: Not required when ordering.

Code	Description	Symbol
<b>B</b>	<b>Single operator, 2 position, spring offset.</b> P to A and B to T in offset position.	
<b>C</b>	<b>Double operator, 3 position, spring centered.</b>	
<b>D</b>	<b>Double operator, 2 position, detent.</b>	
E	Single operator, 2 position, spring offset to center. P to B and A to T in shifted position.	
<b>H</b>	<b>Single operator, 2 position, spring offset.</b> P to B and A to T in offset position.	
K	Single operator, 2 position. Spring offset to center. P to A and B to T in shifted position.	

This condition varies with spool code.

**Bold: Designates Tier I products and options.**

**Non-Bold: Designates Tier II products and options. These products will have longer lead times.**

Inch equivalents for millimeter dimensions are shown in (\*\*)

**A**

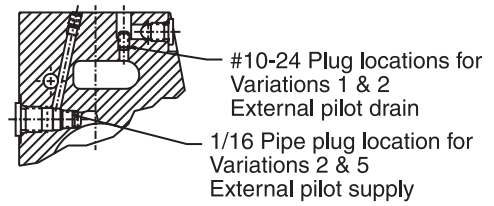
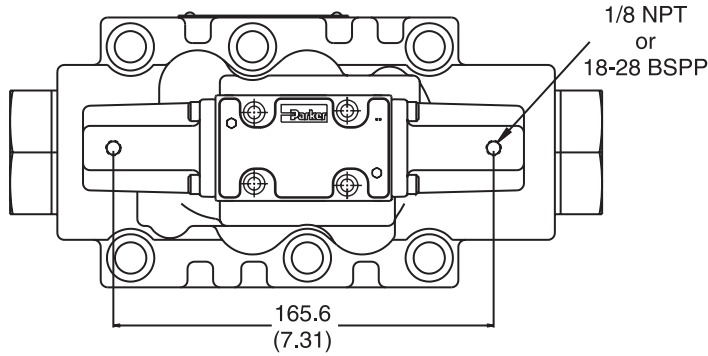

SECTION A-A

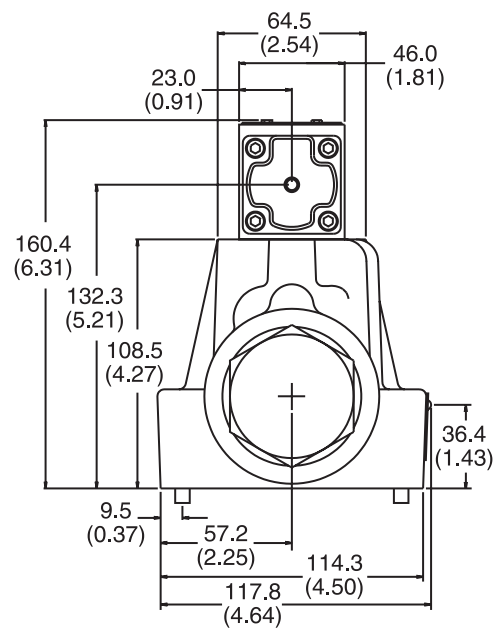
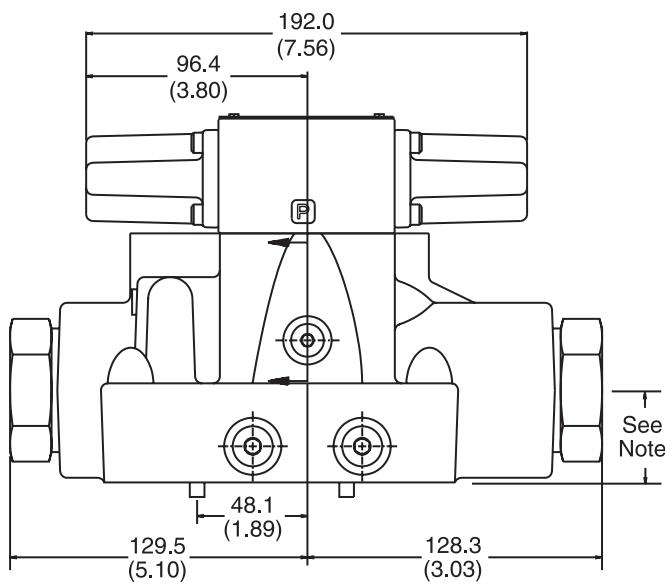

**Note:** 41.9mm (1.65") from bottom of bolt hole counterbore to bottom of valve.



**General Description**

Series D61VL directional control valves are 5-chamber, lever operated valves. They are available in 2 and 3-position styles. They are manifold or sub-plate mounted valves, which conform to NFPA's D08, CETOP 8 mounting patterns.

**Specifications**

<b>Mounting Pattern</b>	NFPA D08, CETOP 8, NG25
<b>Max. Operating Pressure</b>	207 Bar (3000 PSI)
<b>Max. Tank Pressure</b>	Internal Drain Model: 34 Bar (500 PSI) External Drain Model: 207 Bar (3000 PSI)
<b>Maximum Drain Pressure</b>	34 Bar (500 PSI)
<b>Maximum Flow</b>	See Reference Data
<b>Pilot Pressure</b>	Oil Min. 6.9 Bar (100 PSI) Oil Max. 207 Bar (3000 PSI)
<b>Response Time</b>	Varies with pilot line size and length, pilot pressure, pilot valve shift time & flow capacity (GPM)

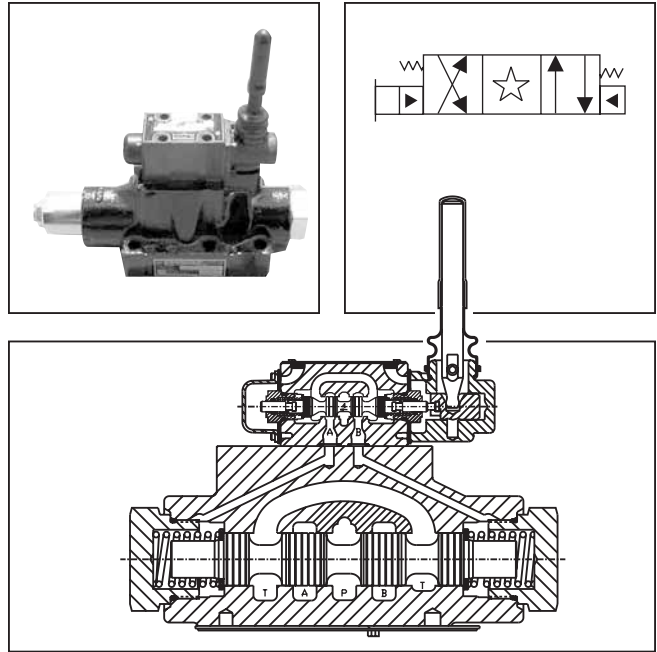

**Ordering Information**

<b>D</b> Directional Control Valve	<b>61V</b> Basic Valve <b>NFPA D08 CETOP 8</b>	<b>L</b> Lever Operated Pilot	□ Spool	□ Style	□ Pilot Supply and Drain	□ Seal	□ Valve Variations	□ Design Series																																
				<table border="1"> <tr><th>Code</th><th>Description</th></tr> <tr><td>1</td><td>Int. pilot/Ext. drain</td></tr> <tr><td>2</td><td>Ext. pilot/Ext. drain</td></tr> <tr><td>4#</td><td>Int. pilot/Int. drain</td></tr> <tr><td>5</td><td>Ext. pilot/Int. drain</td></tr> </table>		Code	Description	1	Int. pilot/Ext. drain	2	Ext. pilot/Ext. drain	4#	Int. pilot/Int. drain	5	Ext. pilot/Int. drain	<table border="1"> <tr><th>Code</th><th>Description</th></tr> <tr><td>N</td><td>Nitrile</td></tr> <tr><td>V</td><td>Fluorocarbon</td></tr> </table>		Code	Description	N	Nitrile	V	Fluorocarbon	<table border="1"> <tr><th>Code</th><th>Description</th></tr> <tr><td>Omit</td><td>Standard</td></tr> <tr><td>7</td><td>Pilot Choke – Meter Out</td></tr> <tr><td>8</td><td>Stroke Adj. 'B' End</td></tr> <tr><td>9</td><td>Stroke Adj. 'A' End</td></tr> <tr><td>60</td><td>Pilot Choke – Meter In</td></tr> <tr><td>89</td><td>Stroke Adj. 'A' &amp; 'B' Ends</td></tr> </table>		Code	Description	Omit	Standard	7	Pilot Choke – Meter Out	8	Stroke Adj. 'B' End	9	Stroke Adj. 'A' End	60	Pilot Choke – Meter In	89	Stroke Adj. 'A' & 'B' Ends	NOTE: Not required when ordering.
Code	Description																																							
1	Int. pilot/Ext. drain																																							
2	Ext. pilot/Ext. drain																																							
4#	Int. pilot/Int. drain																																							
5	Ext. pilot/Int. drain																																							
Code	Description																																							
N	Nitrile																																							
V	Fluorocarbon																																							
Code	Description																																							
Omit	Standard																																							
7	Pilot Choke – Meter Out																																							
8	Stroke Adj. 'B' End																																							
9	Stroke Adj. 'A' End																																							
60	Pilot Choke – Meter In																																							
89	Stroke Adj. 'A' & 'B' Ends																																							

Code	Symbol	Code	Symbol
001		008*	
002		009**	
004		011	
		012	

\* 008 spool has closed crossover.  
 \*\* 009 spool has open crossover.

Valve schematic symbols are per NFPA/ANSI standards, providing flow P to A when energizing operator A. Note operators reverse sides for #8 and #9 spools. See installation information for details.

**Valve Weight:** 12.1 kg (26.7 lbs.)  
**Standard Bolt Kit:** BK227  
**Metric Bolt Kit:** BKM227  
**Seal Kit:**

Nitrile SKD61VL  
 Fluorocarbon SKD61VLV

Code	Description	Symbol
<b>B*</b>	<b>Single operator, 2 position, spring offset. P to A and B to T in offset position.</b>	
<b>C</b>	<b>Double operator, 3 position, spring centered.</b>	
<b>D*</b>	<b>Double operator, 2 position, detent.</b>	
<b>E</b>	Single operator, 2 position, spring centered. P to B and A to T in shifted position.	
<b>H*</b>	<b>Single operator, 2 position, spring offset. P to B and A to T in offset position.</b>	
<b>K</b>	Single operator, 2 position. Spring centered. P to A and B to T in shifted position.	

\*Available with 001, 002, 004, 011, 012.

This condition varies with spool code.

**Bold: Designates Tier I products and options.**

**Non-Bold: Designates Tier II products and options. These products will have longer lead times.**



Inch equivalents for millimeter dimensions are shown in (\*\*)

**A**

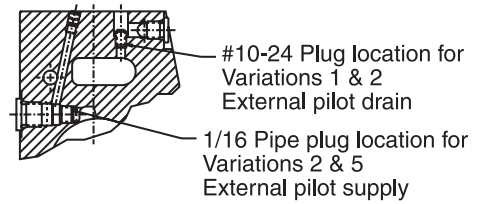
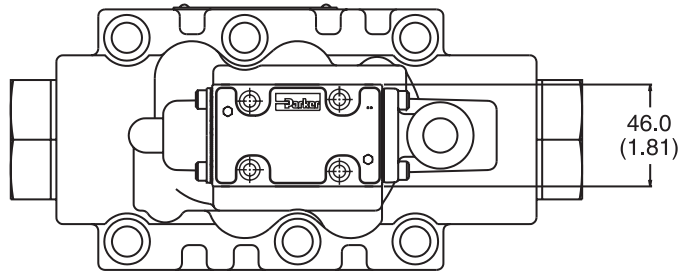

SECTION A-A

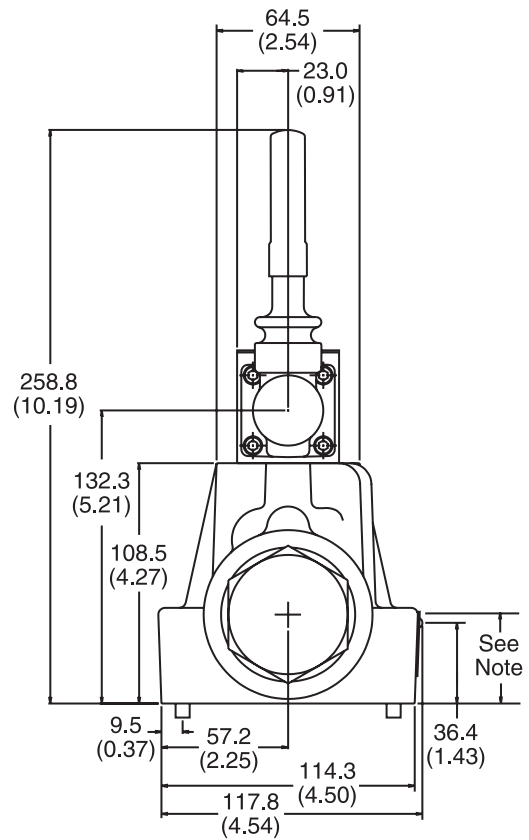
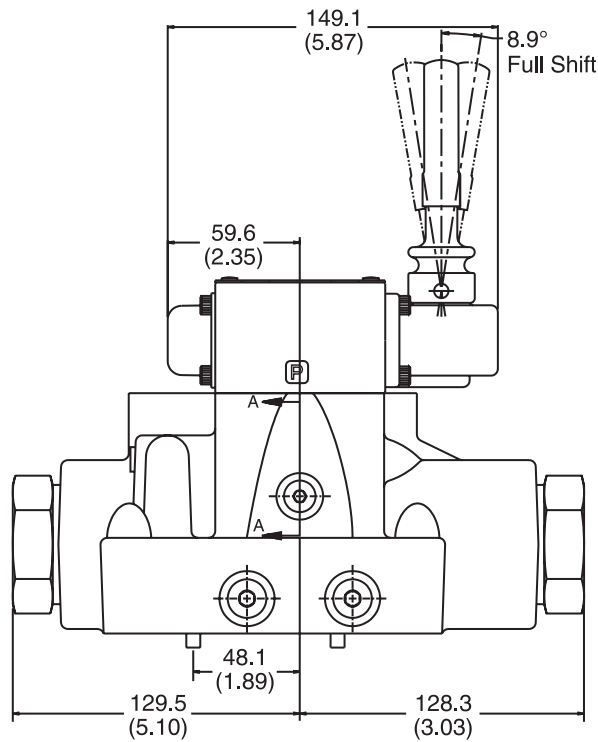

**Note:** 41.9mm (1.65") from bottom of bolt counterbore.



**A**

**General Description**

Series D6P directional control valves are 5-chamber, pilot operated valves. They are available in 2 or 3-position styles. These valves are manifold or subplate mounted, and conform to NFPA's D08, CETOP 8 mounting patterns.

**Features**

- Low pressure drop design.
- Hardened spools provide long life.
- Fast response option available.

**Specifications**

<b>Mounting Pattern</b>	NFPA D08, CETOP 8, NG25
<b>Max. Operating Press.</b>	207 Bar (3000 PSI)
<b>Max. Tank Line Press.</b>	207 Bar (3000 PSI)
<b>Max. Drain Pressure</b>	207 Bar (3000 PSI)
<b>Min. Pilot Pressure</b>	5.1 Bar* (75 PSI)
<b>Max. Pilot Pressure</b>	207 Bar (3000 PSI)
<b>Nominal Flow</b>	189 Liters/Min (50 GPM)
<b>Maximum Flow</b>	See Reference Chart

\* 6.9 Bar (100 PSI) for 2, 8, 9 & 12 spools

For flow path, pilot drain and pilot pressure details, see Installation Information.

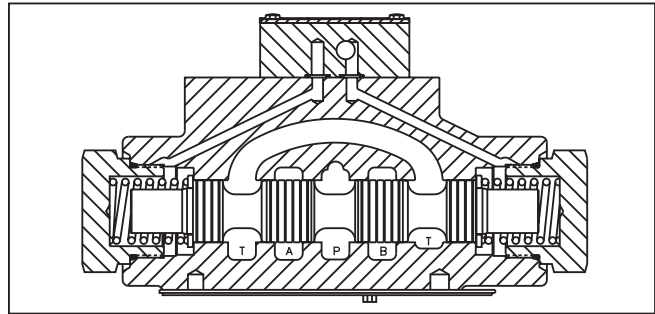
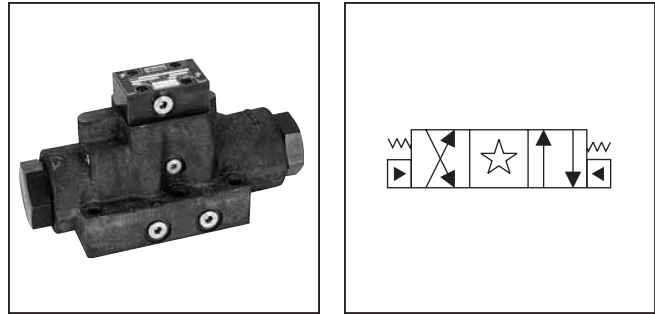

**Response Time**

Response time will vary with pilot line size, pilot line length, pilot pressure shift time and flow capacity of the control valve.

**Shift Volume**

The pilot chamber requires a volume of 0.54 in<sup>3</sup> for center to end and 1.08 in<sup>3</sup> for end to end.

**Ordering Information**

<div style="border: 1px solid black; padding: 2px; width: 30px; margin: 0 auto;">D</div> Directional Control Valve	<div style="border: 1px solid black; padding: 2px; width: 30px; margin: 0 auto;">6</div> Basic Valve	<div style="border: 1px solid black; padding: 2px; width: 30px; margin: 0 auto;">P</div> Hydraulic Pilot	<div style="border: 1px solid black; padding: 2px; width: 30px; margin: 0 auto;"></div> Spool	<div style="border: 1px solid black; padding: 2px; width: 30px; margin: 0 auto;"></div> Style	<div style="border: 1px solid black; padding: 2px; width: 30px; margin: 0 auto;"></div> Pilot Supply and Drain	<div style="border: 1px solid black; padding: 2px; width: 30px; margin: 0 auto;"></div> Seal	<div style="border: 1px solid black; padding: 2px; width: 30px; margin: 0 auto;"></div> Valve Variations	<div style="border: 1px solid black; padding: 2px; width: 30px; margin: 0 auto;"></div> Design Series																									
<div style="border: 1px solid black; padding: 2px; width: 100px; margin: 0 auto;">NFPA D08 CETOP 8</div>																																	
				<div style="border: 1px solid black; padding: 2px; width: 100px; margin: 0 auto;"> <table border="0"> <tr> <th>Code</th> <th>Type</th> </tr> <tr> <td>N</td> <td>Nitrile</td> </tr> <tr> <td>V</td> <td>Fluorocarbon</td> </tr> </table> </div>		Code	Type	N	Nitrile	V	Fluorocarbon																						
Code	Type																																
N	Nitrile																																
V	Fluorocarbon																																
				<div style="border: 1px solid black; padding: 2px; width: 100px; margin: 0 auto;"> <table border="0"> <tr> <th>Code</th> <th>Description</th> </tr> <tr> <td>2</td> <td>Ext. Pilot — Ext. Drain</td> </tr> <tr> <td>5#</td> <td>Ext. Pilot — Int. Drain</td> </tr> </table>           # Available in "B" &amp; "H" styles only.         </div>		Code	Description	2	Ext. Pilot — Ext. Drain	5#	Ext. Pilot — Int. Drain																						
Code	Description																																
2	Ext. Pilot — Ext. Drain																																
5#	Ext. Pilot — Int. Drain																																
						<div style="border: 1px solid black; padding: 2px; width: 100px; margin: 0 auto;"> <table border="0"> <tr> <th>Code</th> <th>Description</th> </tr> <tr> <td>7</td> <td>Pilot Choke — Meter Out</td> </tr> <tr> <td>8</td> <td>Stroke Adj. 'B' End</td> </tr> <tr> <td>9</td> <td>Stroke Adj. 'A' End</td> </tr> <tr> <td>20</td> <td>Fast Response</td> </tr> <tr> <td>60</td> <td>Pilot Choke — Meter In</td> </tr> <tr> <td>89</td> <td>Stroke Adj. 'A' &amp; 'B' Ends</td> </tr> </table>           NOTE: Not required when ordering.         </div>		Code	Description	7	Pilot Choke — Meter Out	8	Stroke Adj. 'B' End	9	Stroke Adj. 'A' End	20	Fast Response	60	Pilot Choke — Meter In	89	Stroke Adj. 'A' & 'B' Ends												
Code	Description																																
7	Pilot Choke — Meter Out																																
8	Stroke Adj. 'B' End																																
9	Stroke Adj. 'A' End																																
20	Fast Response																																
60	Pilot Choke — Meter In																																
89	Stroke Adj. 'A' & 'B' Ends																																
						<div style="border: 1px solid black; padding: 2px; width: 100px; margin: 0 auto;"> <table border="0"> <tr> <th>Code</th> <th>Description</th> <th>Symbol</th> </tr> <tr> <td>1</td> <td></td> <td></td> </tr> <tr> <td>2</td> <td></td> <td></td> </tr> <tr> <td>4</td> <td></td> <td></td> </tr> <tr> <td>8*</td> <td></td> <td></td> </tr> <tr> <td>9**</td> <td></td> <td></td> </tr> <tr> <td>11</td> <td></td> <td></td> </tr> <tr> <td>12</td> <td></td> <td></td> </tr> </table> </div>		Code	Description	Symbol	1			2			4			8*			9**			11			12				
Code	Description	Symbol																															
1																																	
2																																	
4																																	
8*																																	
9**																																	
11																																	
12																																	

\* 8 spool has closed crossover.  
 \*\* 9 spool has open crossover.

Valve schematic symbols are per NFPA/ANSI standards, providing flow P to A when energizing operator X. Note operators reverse sides for #8 and #9 spools. See installation information for details.

**Valve Weight:** 11.0 kg (24.2 lbs.)  
**Standard Bolt Kit:** BK227  
**Metric Bolt Kit:** BKM227

<table border="0"> <tr> <th>Code</th> <th>Description</th> <th>Symbol</th> </tr> <tr> <td><b>B</b></td> <td><b>Single operator, 2 position, spring offset. P to A and B to T in offset position.</b></td> <td></td> </tr> <tr> <td><b>C</b></td> <td><b>Double operator, 3 position, spring centered.</b></td> <td></td> </tr> <tr> <td><b>H</b></td> <td><b>Single operator, 2 position, spring offset. P to B and A to T in offset position.</b></td> <td></td> </tr> </table>	Code	Description	Symbol	<b>B</b>	<b>Single operator, 2 position, spring offset. P to A and B to T in offset position.</b>		<b>C</b>	<b>Double operator, 3 position, spring centered.</b>		<b>H</b>	<b>Single operator, 2 position, spring offset. P to B and A to T in offset position.</b>		<p>This condition varies with spool code.</p>
Code	Description	Symbol											
<b>B</b>	<b>Single operator, 2 position, spring offset. P to A and B to T in offset position.</b>												
<b>C</b>	<b>Double operator, 3 position, spring centered.</b>												
<b>H</b>	<b>Single operator, 2 position, spring offset. P to B and A to T in offset position.</b>												

**Bold: Designates Tier I products and options.**

**Non-Bold: Designates Tier II products and options. These products will have longer lead times.**

D61.indd, dd

Inch equivalents for millimeter dimensions are shown in (\*\*)

**A**

**Standard Pilot Operated**

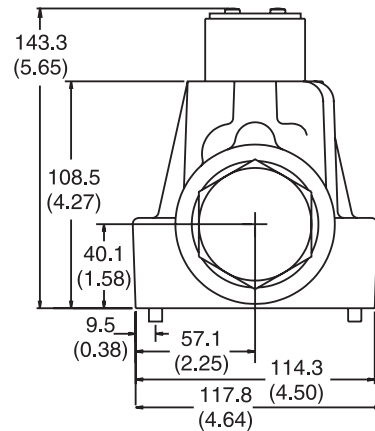
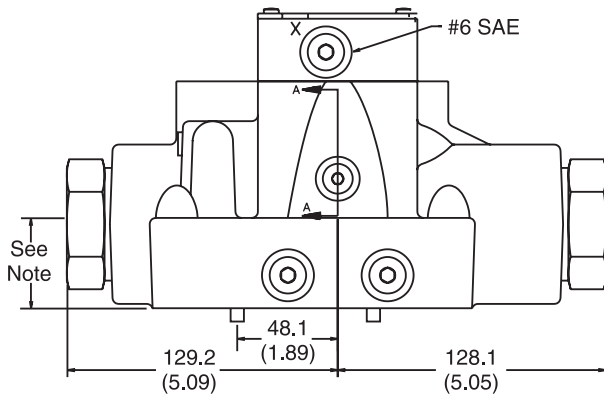
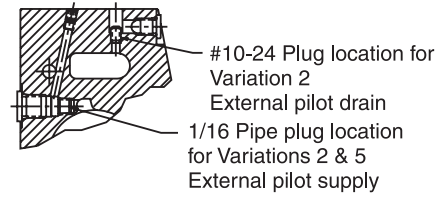
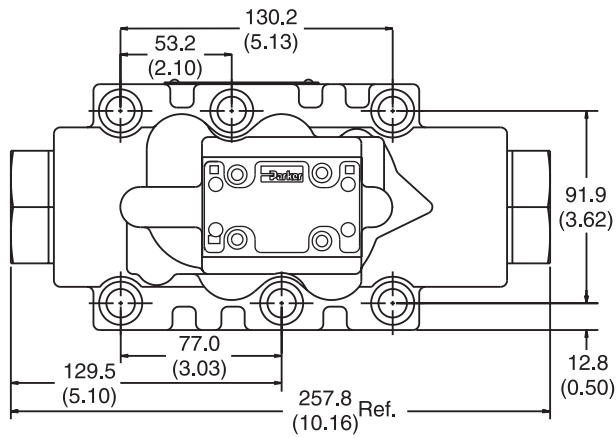

**Note:** 41.9mm (1.65") from bottom of bolt hole counterbore to bottom of valve.

**Pilot Operated with Pilot Choke Control**

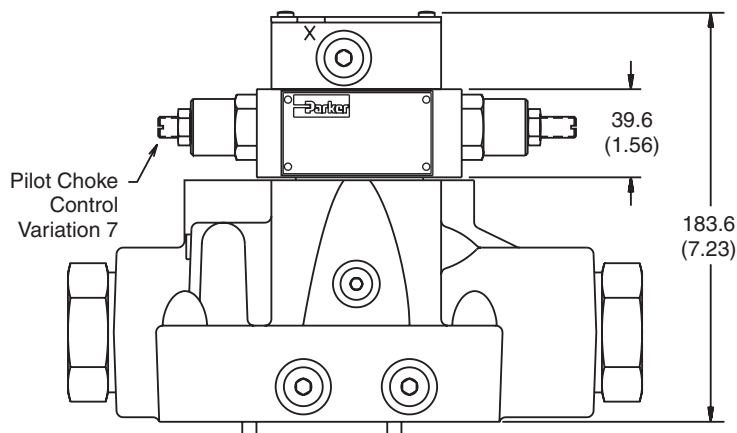

**Note:** 41.9mm (1.65") from bottom of bolt hole counterbore to bottom of valve.

FOR MAXIMUM VALVE RELIABILITY, ADHERE TO THE FOLLOWING INSTALLATION INFORMATION.

The following is important installation information which applies to all directional control valves described in this catalog.

### Mounting Position

Detent – Horizontal  
Spring Offset – Unrestricted  
Spring Centered – Unrestricted

### Fluid Recommendations

Premium quality hydraulic oil with a viscosity range between 32-54 cSt. (150-250 SSU) At 38°C (100°F) is recommended. The absolute operating viscosity range is from 16-220 cSt. (80-1000 SSU). Oil should have maximum anti-wear properties and rust and oxidation treatment.

### Fluids and Seals

Valves using synthetic, fire-resistant fluids require special seals. When phosphate esters or its blends are used, FLUOROCARBON seals are required. Water-glycol, water-in-oil emulsions and petroleum oil may be used with STANDARD seals.

### Filtration

For maximum valve and system component life, the system should be protected from contamination at a level not to exceed 125 particles greater than 10 microns per milliliter of fluid (SAE class 4/ISO 16/13).

### Silting

Silting can cause any sliding spool valve to stick and not spring return if held under pressure for long periods of time. The valve should be cycled periodically to prevent sticking.

### Special Installations

Consult your Parker representative for any application requiring the following:

- Pressure above rating.
- Fluid other than those specified.
- Oil temperature above 71.1°C (160°F).
- Flow path other than normal.

### Mounting Patterns

Series	NFPA	Size
D61V*, D6P	D08, CETOP 8	3/4"

### Torque Specifications

The recommended torque values for the bolts which mount the valve to the manifold or subplate are as follows: 135.6 Nm (100 ft-lbs).

A

**Series D61VW, D61VA, D61VL****Tank and Drain Line Surges**

If several valves are piped with a common tank or drain line, flow surges in the line may cause an unexpected spool shift. Detent style valves are most susceptible to this. Separate tank and drain lines should be piped in installations where line surges are expected.

**Electrical Characteristics (Detented Spool)**

Only a momentary energizing of the solenoid is necessary to shift and hold a detented spool. Minimum duration of the signal is 0.1 seconds for DC voltages. For AC voltages the response time is 0.06 seconds. Spool position will be held provided the spool centerline is in a horizontal plane, and not shock or vibration is present to displace the spool.

**Electrical Failure or Loss of Pilot Pressure (D61VA)**

Should electric power fail or loss of pilot pressure occur, spring offset and spring centered valves will shift to the spring held position. Detented valves will stay in the last position held before power failure. If main flow does not fail or stop at the same time power fails, machine actuators may continue to function in an undesirable manner or sequence.

**Pilot/Drain Characteristics****Pilot Pressure:**

5.1 to 207 Bar (75 to 3000 PSI)  
6.9 Bar (100 PSI) for spools 002, 007, 008, 009 & 014

**External:** An oil source sufficient to maintain minimum pilot pressure must be connected to the "X" port of the main body. When using the external pilot variation, a 1/16" pipe plug must be present in the main body pilot passage. (For details see Dimension pages.) This plug will be furnished in valves ordered with pilot code 2, 3, 5 or 6.

**Internal:** Flow is internally ported from the pressure port of the main valve body to the "P" port of the pilot valve. The pressure developed at the "P" port of the pilot valve must be 5.1 Bar (75 PSI) minimum at all times or 6.9 Bar (100 PSI) for spools 002, 007, 008, 009 & 014.

**Integral Check:** Valves using internal pilot and internal drain with an open center spool (spools 002, 008 & 009) can be ordered with an integral check valve in the pressure port of the main valve codes 3 & 6. Pilot oil will be internally ported from the upstream side of this check to the "P" port of the pilot valve, ensuring sufficient pilot pressure. A 1/16" pipe plug will be present in the main body. The "X" port in the subplate must be plugged when using the integral check.

**Pilot Valve Drain:**

Maximum pressure 102 Bar (1500 PSI), 207 Bar (3000 PSI) optional.

**External:** When using an external drain, a 10 x 24 x 0.31 long set screw must be present in the main body drain passage. (For details see Dimension pages.) This plug will be furnished in valves ordered with drain code 1, 2 or 3.

Drain flow from the pilot valve is at the "Y" port of the main body and must be piped directly to tank. Maximum drain line pressure is 102 Bar (1500 PSI), 207 Bar (3000 PSI) optional. Any drain line back pressure is additive to the pilot pressure requirement.

**Internal:** Drain flow from the pilot valve is internally connected to the main valve tank port. Tank and drain pressure are then identical so tank line pressure should not exceed 102 Bar (1500 PSI), 207 Bar (3000 PSI) optional. Any tank line back pressure is also additive to the pilot pressure requirement. If flow surges (a cause of pressure surges) are anticipated in the tank line, an external drain variation is recommended. The "Y" port in the subplate must be plugged when using an internal drain.

**D61V\* Flow Paths**

Style Code	Description	No Solenoid/Operator Energized	Solenoid/Operator A Energized	Solenoid/Operator B Energized
B	Spring Offset	P→A and B→T	—	P→B and A→T
C	Spring Centered	Centered	P→A and B→T	P→B and A→T
D	Detented	Last Position Held	P→A and B→T	P→B and A→T
E	Spring Centered	Centered	—	P→B and A→T
F†	Spring Offset, Shift to Center	P→A and B→T	—	Centered
H	Spring Offset	P→B and A→T	P→A and B→T	—
K	Spring Centered	Centered	P→A and B→T	—
M†	Spring Offset, Shift to Center	P→B and A→T	Centered	—

† D61VW only.

D61.indd, dd



**Series D6P**

**Tank and Drain Line Surges**

If several valves are piped with a common tank or drain line, flow surges in the line may cause an unexpected spool shift. Detent style valves are most susceptible to this. Separate tank and drain lines should be piped in installations where line surges are expected.

**Loss of Pilot Pressure**

Should a loss of pilot pressure occur, spring offset and spring centered valves will shift to the spring held position. No spring valves will stay in the last position held. If main hydraulic flow does simultaneously stop, machine actuators may continue to function in an undesirable manner or sequence.

**Pilot Drain Characteristics**

**Pilot Pressure:**

5.1 to 207 Bar (75 to 3000 PSI)  
 6.9 Bar (100 PSI) for spools 2, 8, 9 & 12

Direct pilot operated valves use the “X” and “Y” ports to supply pilot oil directly to the ends of the spool, providing spool shifting force. A block mounted on top of the valve body is internally cored to make the necessary connections. Thus when “X” is pressurized, “Y” is used as a drain; and when “Y” is pressurized, “X” becomes the drain.

Any back pressure in these lines when they are being used as a drain is additive to the pilot pressure requirement.

**Internal Drain:** On spring offset models, only the “X” port is pressurized, as the spring returns the spool to its at rest position. On these models, “Y” may be internally drained through the main tank passage in the valve.

**Flow Path/Pilot Pressure**

Style Code	Description	“X” & “Y” De-Pressurized	“X” Port Pressurized	“Y” Port Pressurized	Special Notes	Recommended Control Valve For Pilot Oil
B	Two Position Spring Offset	P→A, B→T	P→A, B→T	P→B, A→T	“X” Port may be pressurized to assist spring in returning spool to offset position (ext. only)	
C	Three Position Spring Centered	Center	P→A, B→T	P→B, A→T	Flow paths will be reversed on valves with tandem center (8) spools	
H	Two-Position Spring Offset	P→B, A→T	P→A, B→T	P→B, A→T	“Y” Port may be pressurized to assist spring in returning spool to offset position	

**Subplate Mounting**  
**NFPA D08, CETOP 8 & NG 25**

**A**

**Recommended Mounting Surface**

Surface must be flat within .102 mm (0.0004 inch) T.I.R and smooth within 812.8 micro-meters (32 micro-inch). Torque bolts to 135.6 Nm (100 ft-lbs).

**Mounting Position**

Valve Type	Mounting Position
Detent (Solenoid)	Horizontal
Spring Offset	Unrestricted
Spring Centered	Unrestricted

**For maximum valve reliability, adhere to the following installation information.**

**Mounting Pattern — NFPA D08, CETOP 8 & NG 25**

Inch equivalents for millimeter dimensions are shown in (\*\*)

